

CHEM-FEED[®]

Plastic Skid System



CFPS-2

**READ THE ENTIRE OPERATING MANUAL
PRIOR TO INSTALLATION AND USE.**



+1 (714) 893 - 8529



sales@blue-white.com



customerservice@blue-white.com



5300 Business Drive
Huntington Beach, CA 92649

Table of Contents

1.0 Introduction	4
1.1 Features	4
1.2 What's in the Box?	5
1.3 Storage and Handling	5
1.4 Product Matrix - CFPS-2	6
2.0 Engineering Specifications	7
2.1 Drawings and Dimensions for CFPS-2	8
2.2 Process and Instrumentation Drawings CFPS-2	9
3.0 Installation	10
3.1 Safety	10
3.2 Tools Required	10
3.3 Mounting Location / Preparation	11
3.4 Installing Components Shipped Loose	11
3.5 Floor Mount	12
3.6 Wall Mount	13
3.7 Mounting Pump(s) to Skid	14
3.8 Pump(s) to Skid Adapters	15
3.9 Input Power Box (optional)	16
3.10 Terminal Box Signal Connection Installation (optional)	16
3.11 Terminal Box Wiring Drawing - Typical	17
4.0 Set-up and Testing	18
5.0 Operation and Calibration	20
5.1 Component Identification -Duplex Skid	20
5.2 Operation - Duplex Skid	21
5.3 Calibration - Duplex Skid	22
6.0 Maintenance	24
6.1 Routine Inspection and Maintenance	24
6.2 Charging Pulsation Dampener	24
6.3 Replacing the Bladder in the Pulsation Dampener	24
6.4 Pressure Relief Valve Maintenance	25
6.5 Skid Component Replacement	26
7.0 General Accessories and Parts List	27
7.1 Accessories	27
7.2 Spare Parts	28
8.0 Troubleshooting	29
9.0 System	30
10.0 Warranty	31

1.0 Introduction

Congratulations on purchasing the CFPS® Chem-Feed Plastic Skid System. The Skid System is designed to inject chemicals into piping systems. The skid has been factory tested by Blue-White® and is ready for use.

Your Chem-Feed® Skid System is pre-configured based on your elections via the product matrix or as designed by our engineering staff.

Please Note: Your new skid has been pressure tested at the factory with clean water before shipping. You may notice trace amounts of clean water in the piping.

CAUTION! Skid is provided only for the application and use for which it is intended. User assumes responsibility for proper operation and maintenance. User is responsible for ensuring skid components are compatible with the chemicals being used. Contact the factory if there are any questions regarding use or compatibility.

1.1 Features

Chem-Feed® Engineered Skid Systems were designed and engineered using solid modeling tools for superior piping installation and easy component maintenance. Custom engineered universal mounting blocks and machined mounting slots provide for easy component servicing and replacement. Each factory built and tested system includes the following components:

- **Pressure Relief Valve** - Protects the system from over-pressurization, 5-150 psi setting range, 150 psi maximum system pressure. Ships on all systems.
 - **Check Valve** - Protects the user from back-flow during pump maintenance. Ships on all systems.
 - **Inlet Y Strainer** - Protects system components from damage cause by dirt or debris.
 - **Calibration Cylinder (optional)** - Confirm pump output under system conditions. Specify cylinder volumes from 1.6 GPH to 128 GPH.
 - **Pulsation Dampener (optional)** - Protect the system components from pulsation. Recommended for diaphragm pump systems. Not recommended for peristaltic pump systems.
 - **Pressure Gauge with Guard** - Isolate and protect the system pressure gauge. Specify pressure ranges from 0-60 psi, 0-160 psi, or 0-300 psi.
 - **Pressure Switch with Guard (optional)** - Activate or de-activate equipment when pressure in a piping system either rises or falls to a set pressure.
 - **Back-Pressure Valve (optional)** - Protects the user from siphon or back-flow, and maintains consistent pressure on pump. Typically used on diaphragm pump systems.
 - **Flow Verification Sensor (optional)** - MS6 accurately verifies chemical feed.
 - **Terminal Box (optional)** - Pump signal wiring is pre-wired to NEMA box for easy access and connection to facility wiring.
 - **Mounting Pads** - Stainless Steel mounting pads to secure Chem-Feed® System to a solid surface. Designed for floor mount or wall mount.
 - **Corrosion Resistant** - Chem-Feed® frame constructed of chemically resistant polyethylene.
 - **Drip Tray** - To collect chemicals and prevent spills. Dual 2.9gal (11.4L)
-

1.2 What's in the Box?

Your Chem-Feed Skid System contains the following:

- Skid (pump not included)(pumps may be ordered separately and installed at factory)
- Components shipped loose (Pressure Gauge, Pulsation Dampener, Calibration Col.) These components may be package in a box strapped to the skid, or wrapped separately and strapped to the skid.
- Mounting brackets (4) and hardware for mounting skid to wall or floor.
- Tubing to connect pump to skid (type of tubing provided will depend on skid matrix selection when skid was ordered.) If pump(s) has been mounted to the skid at the factory, the tubing will already be installed.
- Fitting Kit (type dependent on pump fitting type. [Reference Skid Adapter Sheet.](#)) If pump(s) has been mounted to the skid at the factory, the fittings will already be installed. Additional fittings are provided for the skid inlets and outlets to allow for simple connection to facility piping.
- Certificate of Testing and Quality

1.3 Storage and Handling

The skid is packaged to withstand standard shipping methods. If your skid has arrived with damaged packing, note damage and check contents immediately.

Contact the factory, or local distributor, if the skids, pumps, or components have sustained damage. Shipping damage is not covered under warranty and will be addressed according to Blue-White® freight terms and policy.

If the skid and pumps are not installed at time of arrival, or will be stored for a period of time before installation, they must be stored in original packaging indoors in an air conditioned environment. Do not store skid/pump in excessive heat or freezing temperatures, or in environments with rain or high humidity. Do not stack other boxes or equipment on top of the skid/pump/packaging/box.

When preparing to install the skid and pump, keep it away from excess dust or unusual chemical/moisture exposure. Do not drop or handle in such a way as to cause high impact. Always handle skids and pumps with care.

If there is any question about how to store or handle the pump and accessories, please contact the factory or authorized service center for assistance customerservice@blue-white.com (714) 893-8529.

1.4 Product Matrix - CFPS-2

Model Number Matrix

CHEM-FEED® Duplex Skid System Matrix

CFPS-2	Dual pump system - PE structure														
Inlet/Outlet															
A	Single Inlet / Single Outlet														
B	Single Inlet / Dual Outlet														
X	None, Skid Panel Only														
Piping/Unions															
A	PVC	B	CPVC	C	PVDF	D	Chem Proline®								
Seals															
V	FKM	E	EPDM												
Tubing Connections (Verify tubing connection matches pump outlet when ordering)															
A	1/2" ID PVC Braided	B	1/2" ID PTFE	C	1/4" ID PE	D	1/4" ID PTFE								
Calibration Column															
A	128 GPH (4000 mL) PVC					F	3 GPH (100 mL) PVC								
B	64 GPH (2000 mL) PVC					P	32 GPH (1000 mL) Glass								
C	32 GPH (1000 mL) PVC					Q	16 GPH (500 mL) Glass								
D	16 GPH (500 mL) PVC					R	6 GPH (200 mL) Glass								
E	8 GPH (250 mL) PVC					S	3 GPH (100 mL) Glass								
Pulsation Dampener (One dampener provided. Contact factory for second dampener.)															
P	10 cubic in					X	Not Included								
Back Pressure Valve															
B	Included					X	Not Included								
Pressure Gauge w/Guard															
A	300 PSI				B	160 PSI				C	60 PSI				
Pressure Switch w/Guard															
S	Included					X	Not Included								
Flow Meter w/Strainer															
A	10-5000 mL/m					B	100-10000 mL/m								
X	Not Included														
Terminal Box (includes M12 cables and 120VAC 20A receptacle kit)															
TA	M3S/M4S/MD3S					TD	M3/M4/MD3 (Legacy)								
TB	M1/MD1					X	Not Included								
TC	M2/C2/C3														
Pumps															
P	Mounted*					X	Not Included								
*reference Adapter Kits Sheet 85000-198 when ordering with pumps utilizing "M = 1/2"MNPT" or "F = 1/2"FNPT" connections.															
CFPS-2	*	A	A	V	A	-	A	P	B	A	S	A	TA	P	Sample Model Number

NOTE: When ordering pumps for skids, pump head orientation is standard LEFT facing only. *When ordering skid with pumps of different model numbers, please include complete model number of each pump and location on skid with order. Contact factory for quote/pricing on 5-point performance testing. Customer is responsible for ensuring skid components are compatible with any chemicals being used.

* I = Industrial, M = Municipal

2.0 Engineering Specifications

Skid	Chemically resistant polyethylene structure.
Pump (sold separately)	FLEXFLO® A1/M1, A2/M2, A3/M3 or A4/M4 peristaltic pumps CHEM-FEED® CD1/MD1, C2, C3, or CD3/MD3 diaphragm pumps
Piping	PVC Schedule 80 (optional CPVC, PVDF, Chem Proline®)
Seals	FKM (optional EPDM)
Tubing (T)	Reinforced braided 1/2" PVC, 200 psi max, certified NSF 51 / NSF 61 (optional: 1/2" PTFE, or 1/4" PE, or 1/4" PTFE) The pump inlet and outlet flexible tubing connections are terminated base on type of pump provided. (Refer to Adapter Kits sheet 85000-198)
Tubing Clamps	300 series SS band, 400 series SS screw
Unions (U)	PVC body, schedule 80 (CPVC or PVDF optional)
Ball Valves (V)	Vented ball, True unions, PVC body, PTFE shaft bearings and seats (CPVC or PVDF optional)
Pressure Relief Valve (PRV) Back-Pressure Valve (BPV)	PVC body, PTFE primary diaphragm seal. Non-wetted components: EPDM secondary seal, zinc plated steel spring, stainless steel external hardware, HDPE pressure adjusting screw and locknut. Infinite adjustment from 10-150 psi. Maximum inlet pressure 150 psi. (CPVC or PVDF optional)
Calibration Cylinder (CC)	PVC body, PVC end caps, 1/2" ID PVC pipe outlet vent. Available volumes: 3 GPH (100mL), 8 GPH (250mL), 16 GPH (500mL), 32 GPH (1000mL). 64 GPH (2000mL), 132 GPH (4000mL). (Glass optional - except 2000mL and 4000mL)
Pulsation Dampener (PD)	CPVC body, 10 cubic inch volume, FKM bladder (optional PVDF Body or EPDM bladder)
Gauge W/Guard (G)	Gauge: liquid filled stainless steel with blowout plug, bottom mount, 1/4" NPT threads. Available pressure ranges: 0-60 psi, 0-160, psi, 0-300 psi. Guard: PVC body w/union, PTFE diaphragm seal, temperature compensated oil filled. (Optional CPVC or PVDF)
Check Valve (CV)	PVC body, FKM diaphragm (optional EPDM). Cracking pressure: 1.0-1.5 psi. Maximum working pressure: inlet = 150 psi, back = 100 psi. (CPVC or PVDF optional)
Flow Indicator (F)	Machined cast acrylic, PVC or CPVC connections, ceramic ball, PVDF ball stop, Polypro half unions.
Flow Sensor (MS6)	PVDF and PEEK Body. Available Flow Ranges: 10 - 5,000 ml/min, 100-10,000 ml/min
Y Strainer (S)	PVC body (CPVC or PVDF optional)
Universal Mounting Blocks	PA12
Pump Mounting Brackets (with pump)	316 Stainless Steel
Skid Mounting Foot Pads	316 Stainless Steel
Mounting Hardware	18-8 Stainless Steel
Drip Containment	Duplex Skid -Integral - 2.9 gallons (11.4 L) total containment
Maximum Working Pressure	150 psig (10.3 bar)
Operating Temperature	14 °F to 115 °F (-10 °C to 46 °C)
Approximate Shipping Weight	Duplex Skid - 145 lb. (66.0 kg) - With mounted pumps: up to 265 lb. (120 Kg)
Approximate Shipping Dimensions	60" x 44" x 64"

2.1 Drawings and Dimensions for CFPS-2

Dimensions

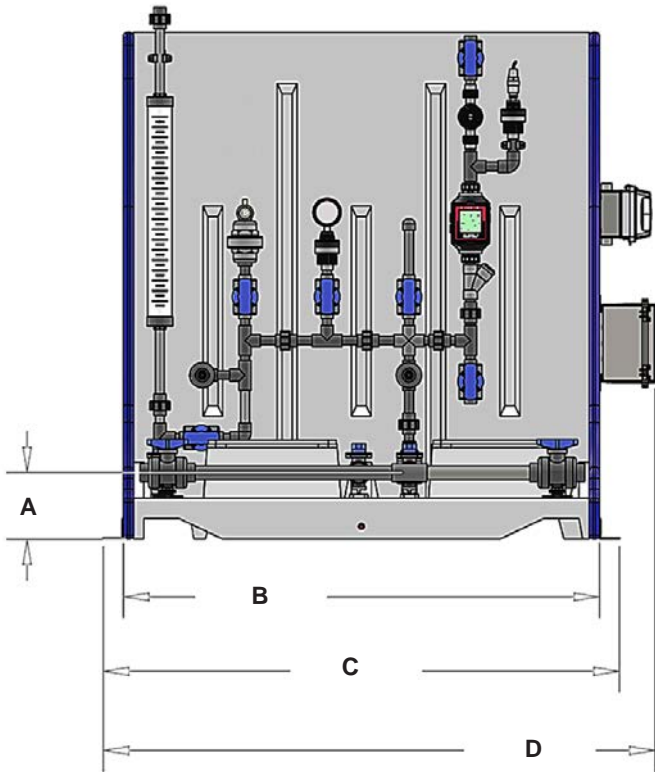

Front View

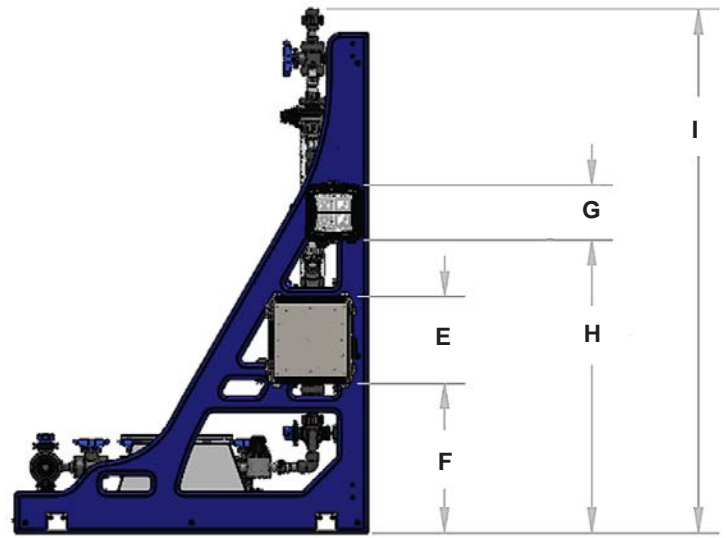

Side View

Dim	Inch	cm	Dim	Inch	cm	Dim	Inch	cm
A	6.48"	16.4	E	8.59"	21.8	I	52.0"	131.9
B	46.5"	118.1	F	14.82"	37.6	J	35"	88.9
C	50.38"	120.8	G	5.43"	13.8	K	3.4"	8.6
D	53.87"	136.8	H	29.03"	73.7			

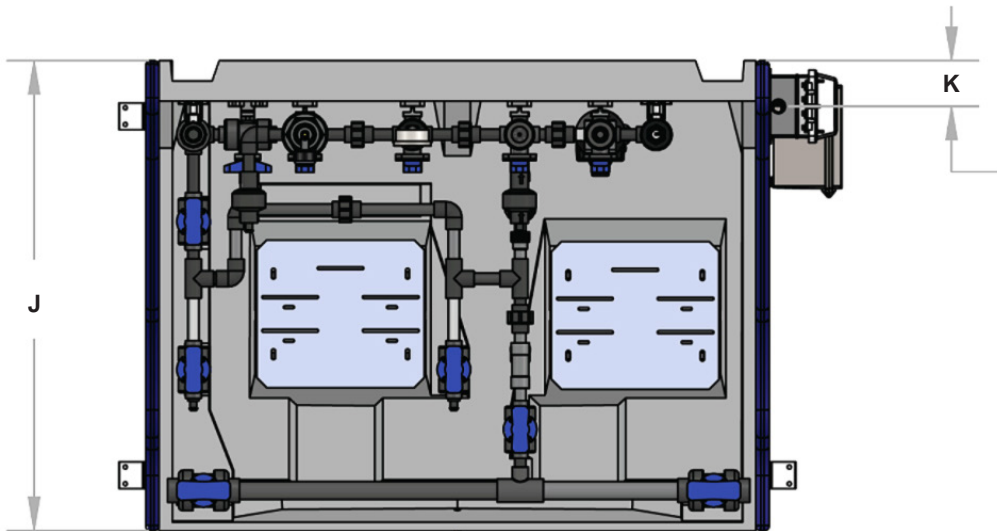

Top View

2.2 Process and Instrumentation Drawings CFPS-2

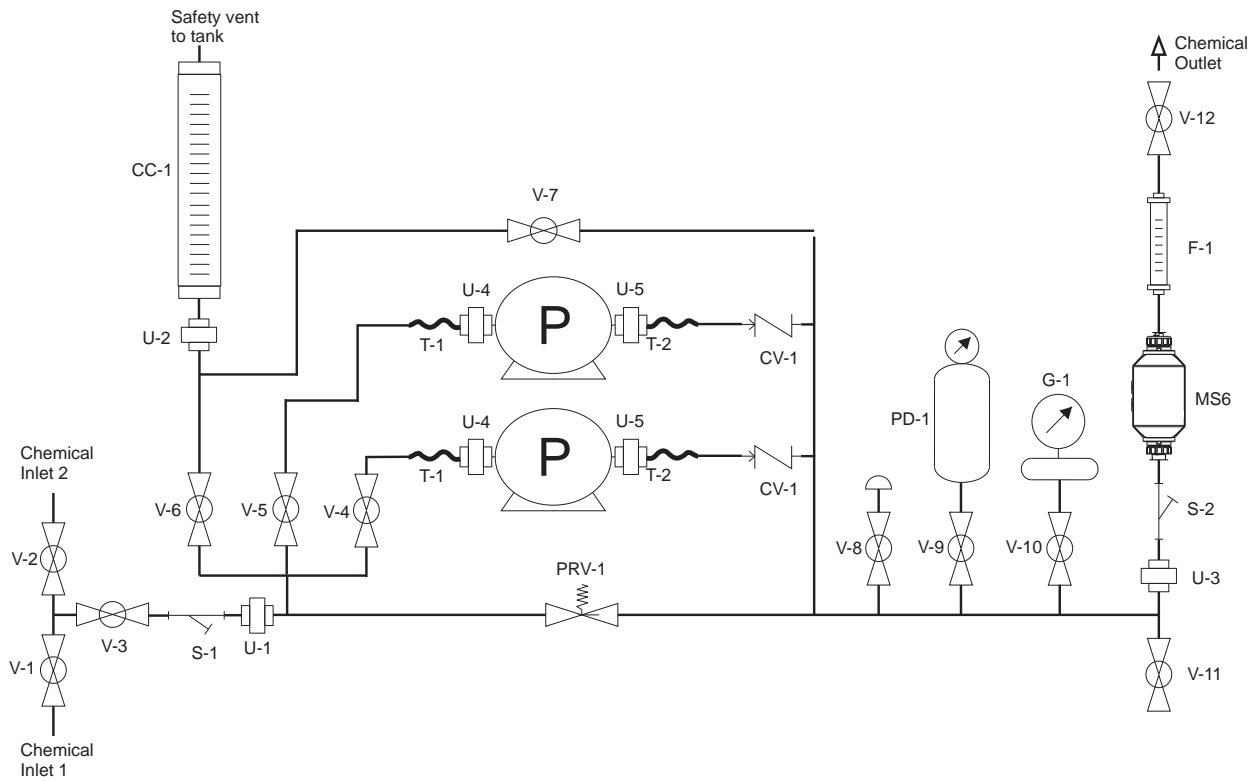

CFPS-2 P&ID

3.0 Installation



CAUTION: Proper eye protection must be worn at all times when installing and servicing the pump.

All diagrams are strictly for guideline purposes only. Always consult an expert before installing the pump into specialized systems. The pump should be serviced by qualified persons only.

3.1 Safety

- Skid is provided only for the application and use for which it is intended.
- User assumes responsibility for proper operation and maintenance.
- User is responsible for ensuring skid components are compatible with the chemicals being used.
- Contact the factory if there are any questions regarding use or compatibility.
- Do not mix chemicals.
- Always wear appropriate safety equipments, including eye protection.
- User is responsible for checking and adhering to local codes and regulations.
- Ensure skid is located in well ventilated area.
- Skid use and installation is intended for qualified personnel only.
- Skid installation requires more than one person. Do not attempt to install without assistance.

3.2 Tools Required

- Level
 - 5/32" Allen wrench (mounting brackets to pump/skid) (provided with pump)
 - 5/8" wrench (floor/wall brackets to skid)
 - 7/16" wrench (check/tighten hardware for pipe supports)
 - Adjustable wrench
 - Flathead screwdriver (tubing clamps and PRV adjustment)
 - Phillips screwdriver (unpacking skid)
 - Any special tools required for mounting to floor or wall (deepening on floor or wall material.)
 - Safety equipment (Safety glasses, gloves, hard hat, etc.)
-

3.3 Mounting Location / Preparation

Choose an area located near the chemical supply tank, chemical injection point and electrical supply. Although the skid and pump(s) are designed to withstand outdoor conditions, a cool, dry, well ventilated location is recommended. Install the skid where it can be easily serviced.

- Ensure the skid is level and mounted at least two feet from walkways and from other equipment.
- When moving and lifting the skid, use rollers or forks under the skid frame. Use care to distribute weight evenly.
- Ensure enough space around electrical boxes and signal boxes for safe access for installation and service
- Mount the skid where the pump can easily be accessed for programming and maintenance.
- When mounting to a wall, ensure the skid is not mounted too high. Pump controls and valves must be easily accessed and view without the use of stools, lifts, or ladders.
- Wall mount to a solid surface only. Mounting to drywall with anchors is not recommended.
- Mount the skid with inlet and outlet plumbing pre-planned. Inlet and outlet piping is the responsibility of the owner/user. Ensure any installed piping does not interfere with skid piping or electricals.
- Review mounting location in relation to feed tank level. Determine if pump will have flooded suction or suction lift.
- Review location of calibration column ventilation outlet in relation to feed tank elevation. Extend ventilation piping, or return to tank, as needed to prevent accidental spilling during calibration or pumping.
- Do not mount or support other equipment from the skid frame.

3.4 Installing Components Shipped Loose

Depending on the skid configuration, there may be skid components shipped loose. These components are shipped loose to maintain to prevent damage which may occur during shipping. These components are:

- Calibration Column
- Pressure Gauge
- Pulsation Dampener

Install these components by referring to the skid diagrams for location and alignment. All components have unionized connections. Ensure all O-rings are present and seated properly before installation.

Hand tighten unions only. Do not use tools. If there are any questions regarding the installation of loose components, please contact the factory for assistance.

3.5 Floor Mount

Choose an area located near the chemical supply tank, chemical injection point and electrical supply. Although the pump is designed to withstand outdoor conditions, a cool, dry, well ventilated location is recommended. Install the pump where it can be easily serviced. If installing the pump on a pedestal or table, ensure final weight can be supported.

- Locate Skid in an area where inlet and outlet piping is easily accessed. Ensure proper spacing for electricals and electrical boxes. Ensure skid is level.
- Mount brackets to skid using provided ¼-20 Bolts. Brackets are provided/shipped installed for floor mounting.
- Place the skid and mark holes on the floor or wall surface.
- Remove the skid and drill holes into the floor surface. Check surroundings and accessibility before securing the skid frame.
- Place the skid and secure it to the base/wall surface using the appropriate hardware for the base surface. ¼-20 bolts are recommended.

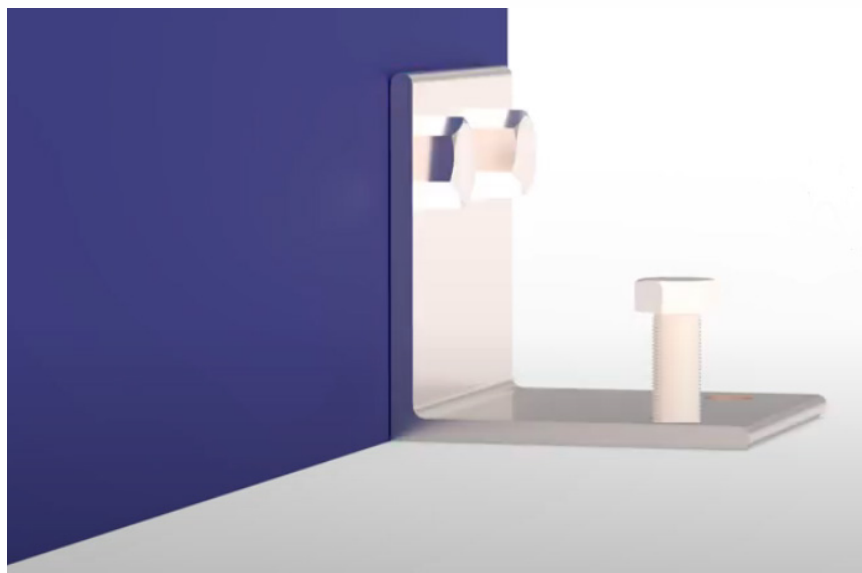
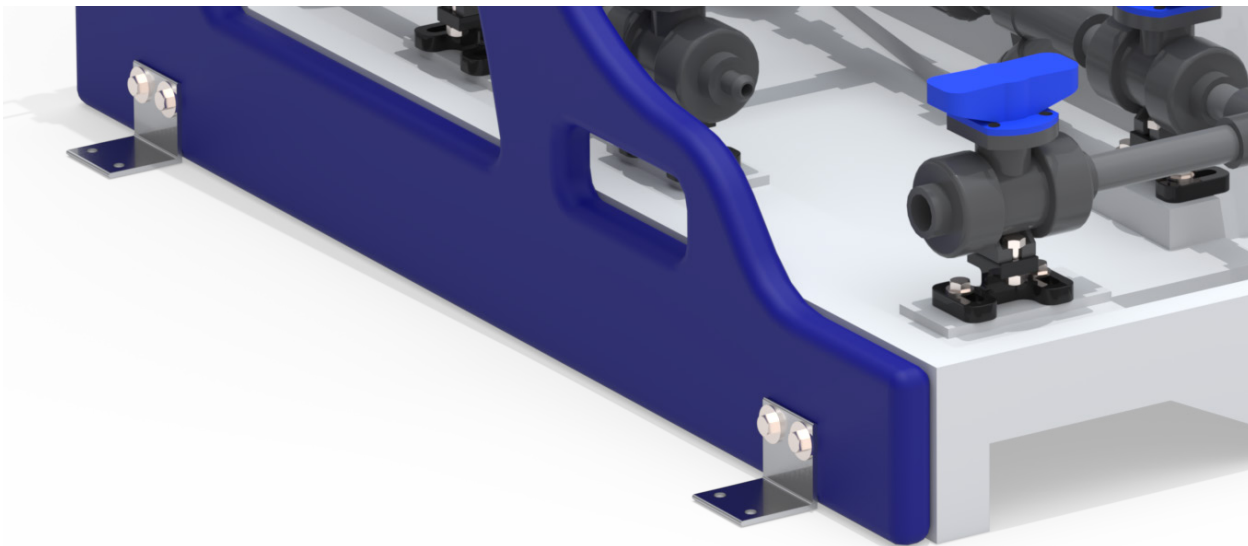

3.6 Wall Mount

Choose a wall location with enough clearance for skid. Determine proper height of skid. We recommend a height where all valves can easily be accessed and pump control screen is easy to read.

- Measure and mark wall to ensure skid is level. Drill anchor holes as appropriate for wall surface. Use 1/4-20 anchor bolts or similar to support weight of skid.
- Remove angle mounting brackets from skid (skid is shipped with mounting brackets attached for floor mounting.) Re-attach brackets on tapped hole locations on each side of the skid (4 total.) Ensure brackets are secure.
- We recommend mounting the pump(s) after the skid is mounted to the wall, as lower weight will allow for easier installation.
- Lift skid into mounting location on wall. Use temporary supports, table, and additional personnel to assist with this step.
- Mark mounting holes on wall, or ensure proper location of other mounting media such as Unistrut, etc. Drill and clean holes or prep hardware, as appropriate. Raise skid and secure bolts through mounting brackets and into wall/strut. Ensure all bolts and/or nuts are secure before proceeding.
- Do not mount or support any other equipment from skid. Do not allow operators or maintenance personnel to use skid as a step or support surface.



3.7 Mounting Pump(s) to Skid

If pumps are not already mounted to the skid, you will need to mount the pump and connect suction and discharge tubing. Depending on the pump and controls being used, you may also need to connect power and signal/communication wiring.

To mount the pump(s) to the skid:

- Ensure you have all provided hardware before mounting pump(s)
- Mount brackets to pump. Use hardware provided with pump. (4 x 10-32 x.50 soc cap)
- Place pumps (with bracket installed) on to pump pedestal.
- Align the pump with mounting holes.
- Use provided hardware to attach brackets to pedestal.
- Ensure pump is secured and does not move.

Connect skid tubing to pump:

- Connect suction tubing and discharge tubing using provided Adapter Kits (as appropriate for accompanying pumps. See next page.)
- Connect power and signal wiring (Refer to pump manual for specific wiring details):
- Connect power cord to pump. Plug power cord into appropriate receptacle, or Input Power Box provided with skid.
- Connect M12 signal cables to pump. (M12 cables provided if skid is ordered with Terminal Box.)
Be sure to pay attention to cable labeling. Do not plug M12 cable to pump without confirming proper location. Connecting M12 cables to incorrect location may cause damage to pump!

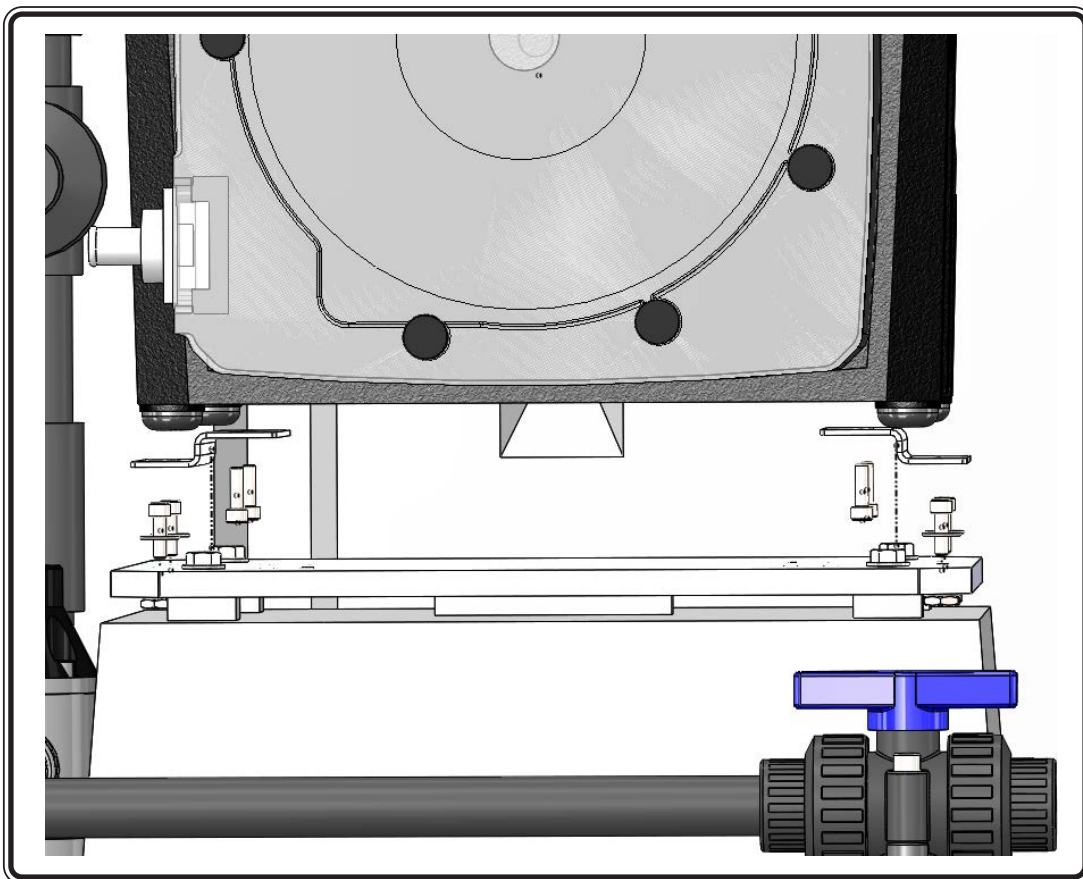

3.8 Pump(s) to Skid Adapters

If your skid was ordered with pumps installed at the factory, the adapters and tubing will already be connected and installed. Pumps mounted onto the skid in the field will require connection and installation tubing between pump and skid. Adapter kits must be ordered with skid, depending on type of pump connection.

PUMP to SKID - ADAPTER KITS

An adapter kit must be added to skid orders (single, duplex, triplex) with the following pumps:

A1, M1, A2, M2, A3, M3, A4, M4. (with “M” type tube fittings)

C2, C3. (with “F” type connections.)

(Kits are not necessary when ordering CD3 or MD3 pumps, or pumps with “S”, “B”, or “Q” tube fittings.)

Number of adapter kits ordered must equal number of pumps.

No extra charge for the Kits when ordered with skids.

A1/M1 Pumps with “M” type tube fittings



KIT-CSP Kit Coupling S/A .37T .50F/NPT PVC

KIT-CSC Kit Coupling S/A .37T .50F/NPT CPVC



KIT-CBP Kit Coupling S/A .50 Barb .50F/NPT PVC

KIT-CBC Kit Coupling S/A .50 Barb .50F/NPT CPVC

A2/M2, A3/M3, A4/M4 Pumps with “M” type tube fittings



KIT-USPV Kit Union S/A .37T .50F/NPT PVC/FKM

KIT-USPE Kit Union S/A .37T .50F/NPT PVC/EP

KIT-USCV Kit Union S/A .37T .50F/NPT CPVC/FKM

KIT-USCE Kit Union S/A .37T .50F/NPT CPVC/EP



KIT-UBPV Kit Union S/A .50 Barb .50F/NPT PVC/FKM

KIT-UBPE Kit Union S/A .50 Barb .50F/NPT PVC/EP

KIT-UBCV Kit Union S/A .50 Barb .50F/NPT CPVC/FKM

KIT-UBCE Kit Union S/A .50 Barb .50F/NPT CPVC/EP

C2/C3 Pumps with “F” type connections



KIT-EBP Kit Elbow S/A .50 Barb .50 M/NPT PVC

3.9 Input Power Box (optional)

Be certain to connect the pump to the proper supply voltage. Using the incorrect voltage will damage the pump and may result in injury. The voltage requirement is printed on the pump serial label.

Caution: When in doubt regarding your electrical installation, contact a licensed electrician.

Check specific pump or accessory manual for specific instructions on wiring the pump and other accessories.

3.10 Terminal Box Signal Connection Installation (optional)

Optional Terminal Box provided with skid:

Wiring instructions will be provided with the Terminal Box, including wiring diagrams. Review all drawings and manuals prior to connecting any signal wiring.

1. Open the enclosure front panel.
2. Inspect all terminal blocks and existing M12 cable wiring connections.
3. Check for loose wires.
4. Review wire labeling.
5. Bring in facility signal wiring and land wires.
6. Review connections and test.
7. Connect M12 cables to pumps. Ensure cables are connected to proper location. M12 cables connected to incorrect connector may cause damage to pump.

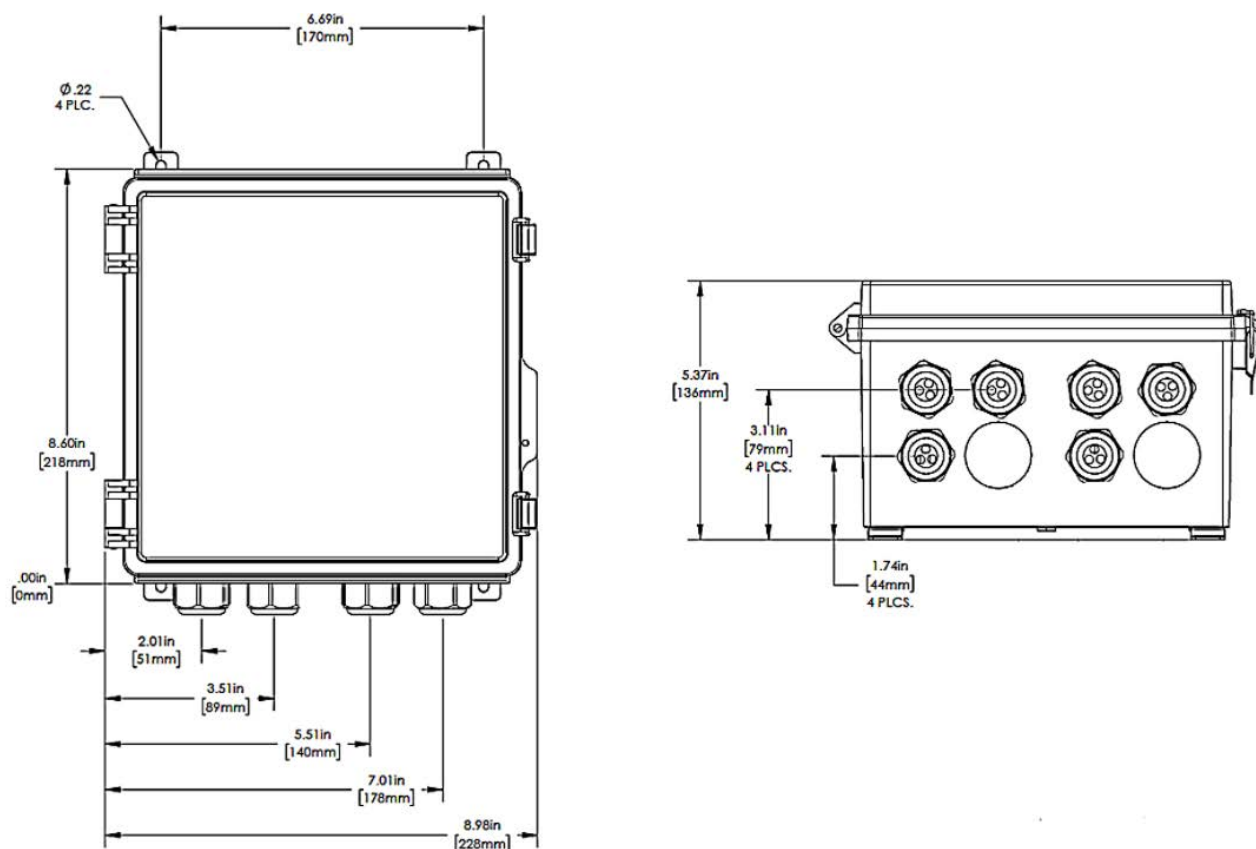

3.11 Terminal Box Wiring Drawing - Typical

Note: Figure shown is typical single pump wiring for single “S” Series pump. Actual wiring for terminal box will depend on pump type and pump quantity of ordered terminal box.

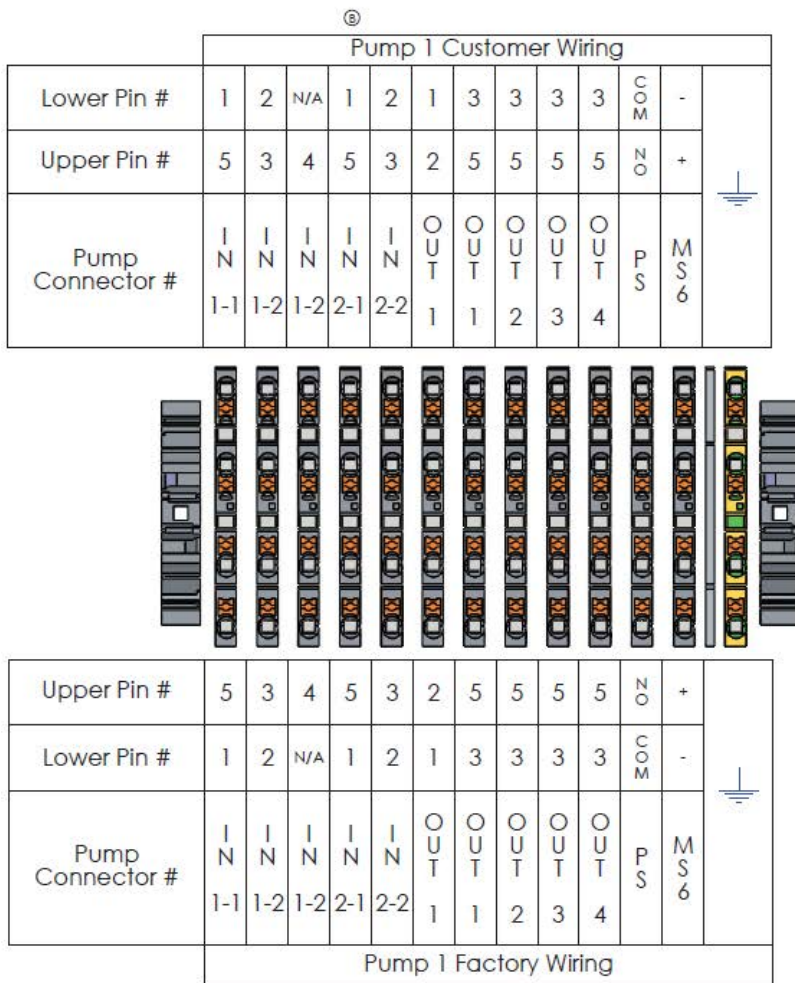

Pump Connector	Pin #	Rating	Wire Color	Description	Electrical SP.
Input #1-1	1	Open= Stop GND = Run	Brown	Remote Start/Stop #1 (Dry Contact)	0 VDC
	5	(-)	Gray		
Input #1-2	2	FVS (+)	White	FVS	15 VDC at 60mA SUPPLY 5 VDC SIGNAL
	3	FVS (-)	Blue		
	4	FVS (SIGNAL)	Black		
Input #2-1	1	Open= Stop GND = Run	Brown	Remote Start/Stop #2 (Dry Contact)	0 VDC
	5	(-)	Gray		
Input #2-2	2	(+)	White	4-20mA Input	250ohm impedance, Non-powered loop
	3	GND	Blue		
Output #1	1	(+)	Brown	4-20mA Output	250ohm impedance, Non-powered loop
	2	(-)	White		
Output #1	3	NORM. OPEN	Blue	Relay Output #1	Form C 1 Amp Max at 125VAC 0.8 Amp Max at 30VDC
	5	COMMON	Gray		
Output #2	3	NORM. OPEN	Blue	Relay Output #2	Form C 1 Amp Max at 125VAC 0.8 Amp Max at 30VDC
	5	COMMON	Gray		
Output #3	3	NORM. OPEN	Blue	Relay Output #3	Form C 1 Amp Max at 125VAC 0.8 Amp Max at 30VDC
	5	COMMON	Gray		
Output #4	3	NORM. OPEN	Blue	Relay Output #4	Form C 5 Amp Max at 250VAC 5 Amp Max at 30VDC
	5	COMMON	Gray		
Pressure Switch		NORM. OPEN	Blue	Pressure Switch	Form C 1 Amp Max at 125VAC 0.8 Amp Max at 30VDC
		COMMON	White		
MS6 FLOW METER	-	NEGATIVE	N/A	MS6 4-20mA Output	120ohm impedance, Powered loop
	+	POSITIVE	N/A		

NOTE: FVS, PRESSURE SWITCH, AND MS6 PRE-WIRED ONLY IF OPTIONS ARE INCLUDED IN BLUE-WHITE SKID SYSTEM; ELSE, TERMINALS OPEN AS SPARES.

4.0 Set-up and Testing

Prior to Operation - System Review

After the CFPS Skid has been installed, all components should be checked again for proper alignment and secure connections.

Ensure all unions are tight and hardware are supports are secure.

Check electrical connections and wiring. Prior to fluid testing, we recommend powering on pump(s), testing controls, and familiarizing yourself with pump programming.

- Temporarily disconnect suction and discharge tubing from the pump.
- Run the pump dry in manual mode.
- Test all communication wiring and program pump inputs and outputs.
- If using a peristaltic pump, test pump leak detection.

Review material compatibility of all skid components with the chemical being used. If there is any doubt about chemical compatibility, please contact the factory prior to use. It is the customer's responsibility to ensure all skid components are compatible with the chemicals being used.

We recommend reviewing the individual manuals for each skid component if there is any question as its functionality, performance, or chemical resistance.

Skid Testing

All Blue-White® skids are leak tested at the factory prior to shipment. **However, we do recommend testing the skid for leaks prior to use, as connections and fittings can loosen during shipment.**

After all of the skid connections and wiring have been checked, a water test is recommended to check for any leaks. **(Caution: If using chemical that are incompatible with water, such as sulfuric acid or polymers, use alternate leak testing method, or/and ensure all water is removed from piping and components before introducing chemicals.)**

This is a good time to review valve positioning.

Put the pump(s) in "Off" or "Manual" mode and ensure it is not running. Test the skid with water by using one of the skid inlets connected to a low-pressure water source or tank.

1. Open inlet valve V1 or V2 to the skid.
 2. Open the suction valve to the pumps.
 3. Open discharge valve (V12 for Dual skid.)
 4. Turn the pump on.
 5. Run the pump in manual mode slowly. Slowly increase the speed as needed to draw water into the skid system.
 6. Once water begins to exit the skid's discharge, turn the pump off.
 7. Check all valves and union seats.
 8. Check the piping for leaks.
 9. Open the valve to the calibration column and fill the calibration column.
 10. Stop the pump and check for leaks.
-

Pressure Testing

All Blue-White® skids are pressure tested at the factory. We recommend performing a pressure test on site and testing the provided **Pressure Relief Valve (PRV)**.

- Once the skid has been filled and leak-tested with water, the system can be pressure-tested, and the Pressure Relief Valve (PRV) can be set and tested. The CFPS Skid System is rated for 150 PSI; however, depending on the pump model provided and other factors, the system must be protected from running at excessively high pressure.
- A pressure relief valve (PRV) is provided with the skid to ensure the skid or system does not see high pressures. The pressure relief valve is set at the factory for 50 PSI. The pressure setting on the PRV can be changed by turning the set screw on the PRV.

To test the PRV

1. Open suction and discharge valves and run the pump at a slow speed, about 1-5% speed.
2. Ensure the valve to the pressure gauge is open.
3. Slowly close the discharge valve on the skid until the pressure gauge begins to move.
4. Close the valve very slowly and watch the pressure gauge.
5. The pressure should stop increasing once it reaches the set point of the PRV (typically 50 PSI). The PRV will open and recirculate water back into the suction side of the pump.
6. To adjust the PRV setting, leave the pump running and turn the PRV set screw to adjust the pressure setting. One complete turn equals approximately 25 psi change.
7. Turning clockwise will tighten the valve and increase the system pressure. Turn the PRV counter-clockwise to set a lower pressure.
8. Be careful not to exceed the pressure rating of the pump or tubing. **Pay special attention to the pressure rating of tube assemblies on peristaltic pumps.**
9. We recommend setting the PRV to 10 psi over the desired maximum running pressure system pressure.
10. **If using a Pressure Switch in your discharge piping outside the skid, test it at this time.** Adjust the pressure switch as necessary to provide a signal at a pressure just below the PRV Pressure setting.

[Refence Section 6.4 for instructional video on PRV Maintenance and Adjustment](#)

- Check for leaks after running the skid system at pressure.
 - Open the discharge valve completely and run the system with zero pressure for about 10-30 minutes. Check for leaks.
 - If leaks occur at welded pipe connections or accessory components, contact the factory. If leaks occur at valves or unions, stop the pump/system and relieve pressure. Then, check valve O-rings to ensure they are seated properly.
 - Drain the system if desired or required.
-

5.0 Operation and Calibration

5.1 Component Identification -Duplex Skid

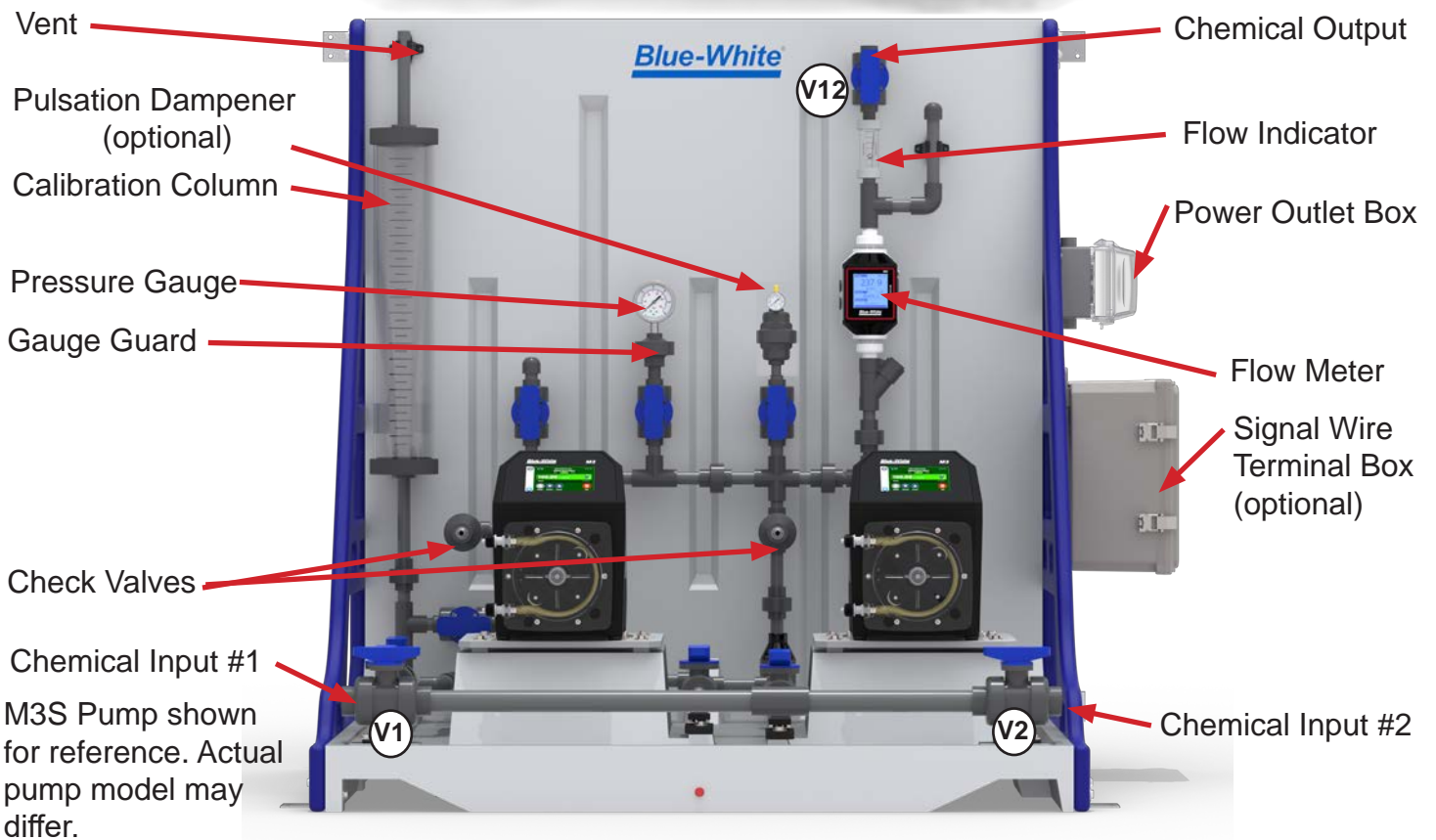
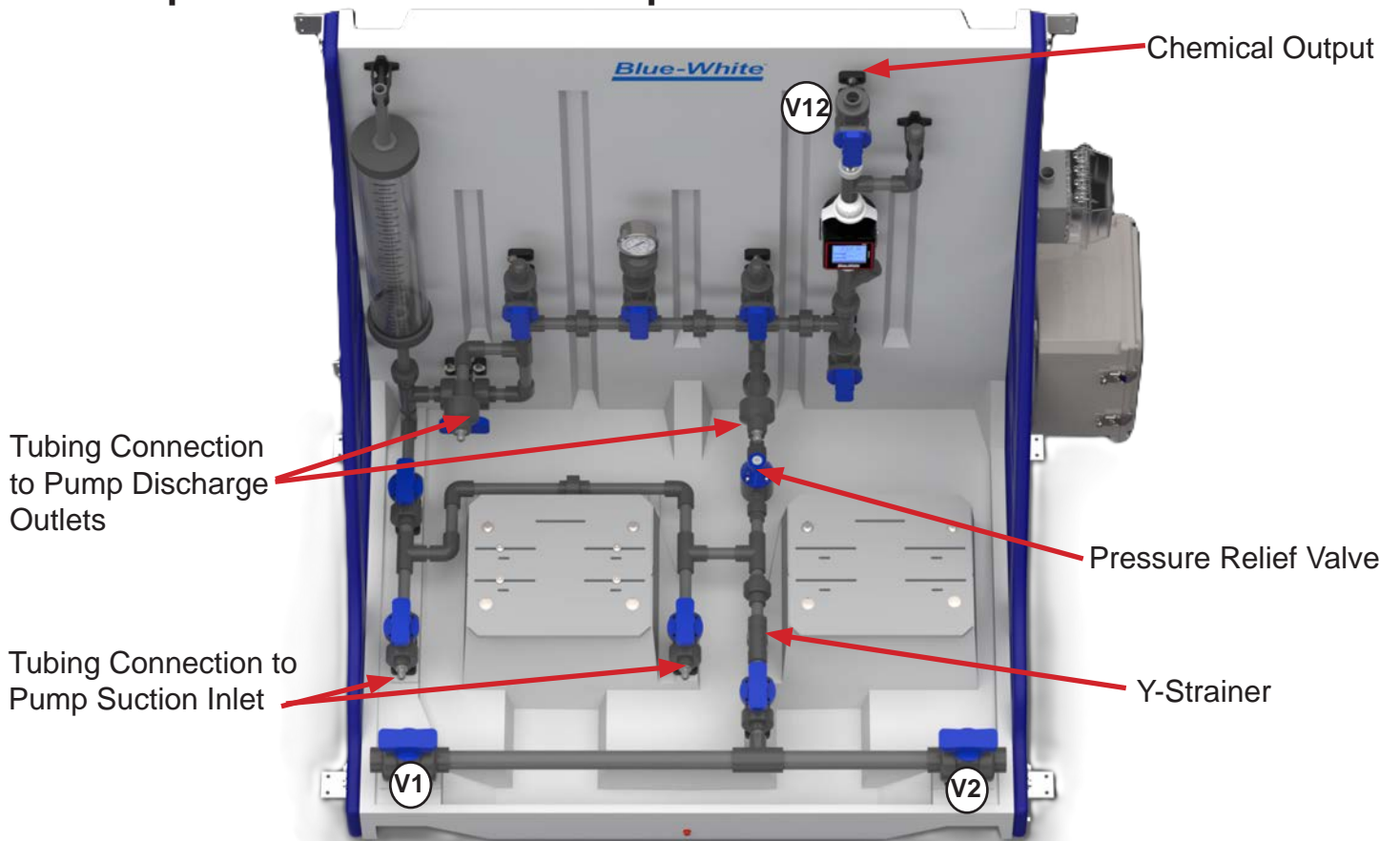

5.2 Operation - Duplex Skid

Before priming the pump(s), or starting the pump(s), be sure that all suction and discharge lines are connected properly and that proper valves are open. Review all discharge piping to ensure valves are open to the proper discharge location.

The priming process and controls may be different depending on the pump model. Check pump model instructions on the best way to prime the pump.

To Pump chemical solution into CFPS Duplex Skid System.

1. Open ball valve V-1 or V-2, depending on your inlet side.
2. Open ball valve V-3, and V-4 or V-5, depending on which pump is being used.
3. Close ball valve V-6 and V-7.
4. Open ball valve V-12 to inject chemical solution into your system.
5. Start pump.
6. Once the system is primed, put the pump into the desired operating mode and speed.

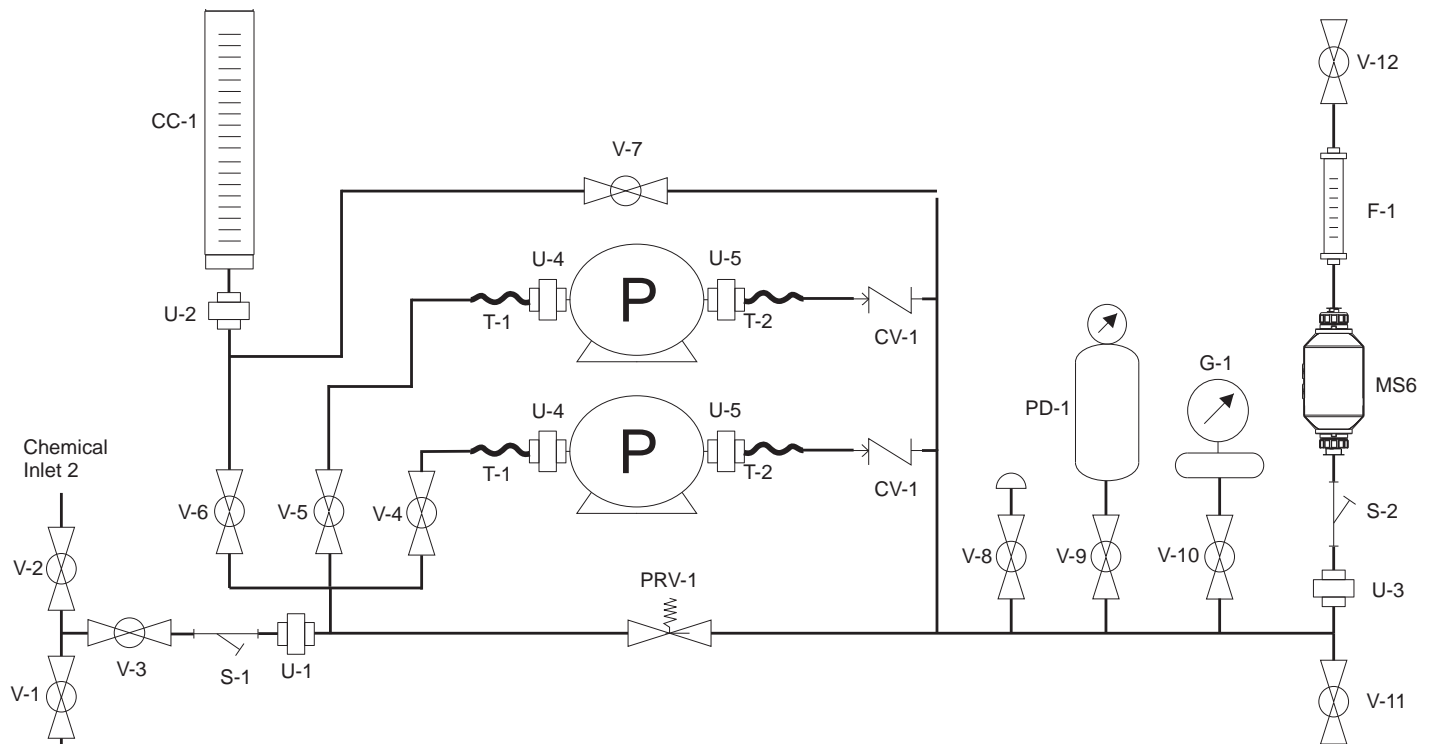

5.3 Calibration - Duplex Skid

If pump calibration is desired, use the provided skid calibration column to calibrate the pump. Calibrating the pump ensures the flow rate reading is accurate to the actual flow provided by the pump. Since flow rates can vary with pressure, suction line conditions, chemical type, viscosity, and other factors, it is desirable to perform a pump calibration to ensure accurate chemical injection.

Calibration of the pump may be slightly different depending on the pump technology being used. Please refer to the instruction manual for your pump to adjust feed rate and calibration instructions.

- **Diaphragm pump calibration** is more accurate when calibrating against actual system pressure. This means pulling from the calibration column and pumping into the actual system pressure or against a back-pressure valve set to desired pressure.
- **Peristaltic pump calibration** is more accurate when pulling from the actual suction line conditions at the maximum desired flow rate. This means pulling from the actual chemical tank and discharging into the calibration column.

To calibrate a diaphragm pump on a Duplex Pump Skid:

1. Fill the calibration column*. Open ball valve V-1 or V-2, depending on your inlet side.
2. Open ball valve V-4/5 and V-7.
3. Close ball valve V-6, V-11, and V-12.
4. Start pump and run until calibration cylinder is filled to top calibration line, or to your desired measurement point. **Do not leave pump unattended during this operation.**
5. Stop pump once calibration cylinder reaches the desired level.
6. Calibrate the pump. Close ball valves V-1/2, V-3, and V-7.
7. To inject chemical solution into your system, open ball valve V-6 and V-12.
8. Note the chemical solution level in the calibration cylinder.
9. To calibrate pump at maximum speed into your system, Press the prime button on pump. The prime mode runs the pump at maximum speed for 60 seconds (1 minute) on most Blue-White® pumps. **Ensure the Cal. Column is large enough for this volume.** If not, calibrate pump for 30 seconds manually or at a lower feed rate. You must program your pump speed before running this routine.
10. Note the chemical solution level after pump is stopped.

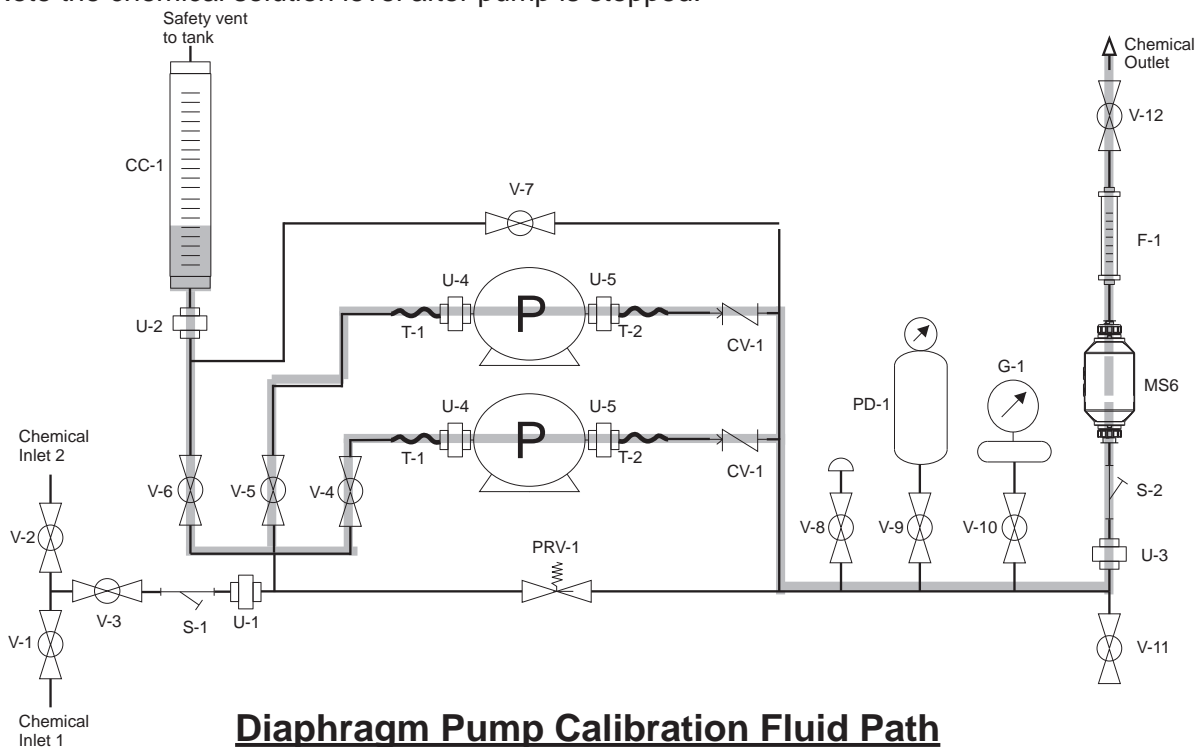

To calibrate a peristaltic pump on a Duplex Pump Skid:

1. Fill the calibration column*. Open ball valve V-1 or V-2, depending on your inlet side.
2. Open ball valve V-4/5 and V-7.
3. Close ball valve V-6, V-11, and V-12.
4. Start pump and run until calibration cylinder is filled to the bottom calibration line, or to your desired measurement point. Leave enough room in the column to ensure column do not over-fill during calibration. **Do not leave pump unattended during this operation.**
5. Stop pump once calibration cylinder is at desired level.
6. Calibrate the pump. Note the chemical solution level in the calibration cylinder.
7. To calibrate pump at maximum speed into your system, Press the prime button on pump. The prime mode runs the pump at maximum speed for 60 seconds (1 minute) on most Blue-White® pumps. **Ensure the Cal. Column is large enough for this volume.** If not, calibrate pump for 30 seconds manually or at a lower feed rate. You must program your pump speed before running this routine.
8. Note the chemical solution level after pump is stopped.

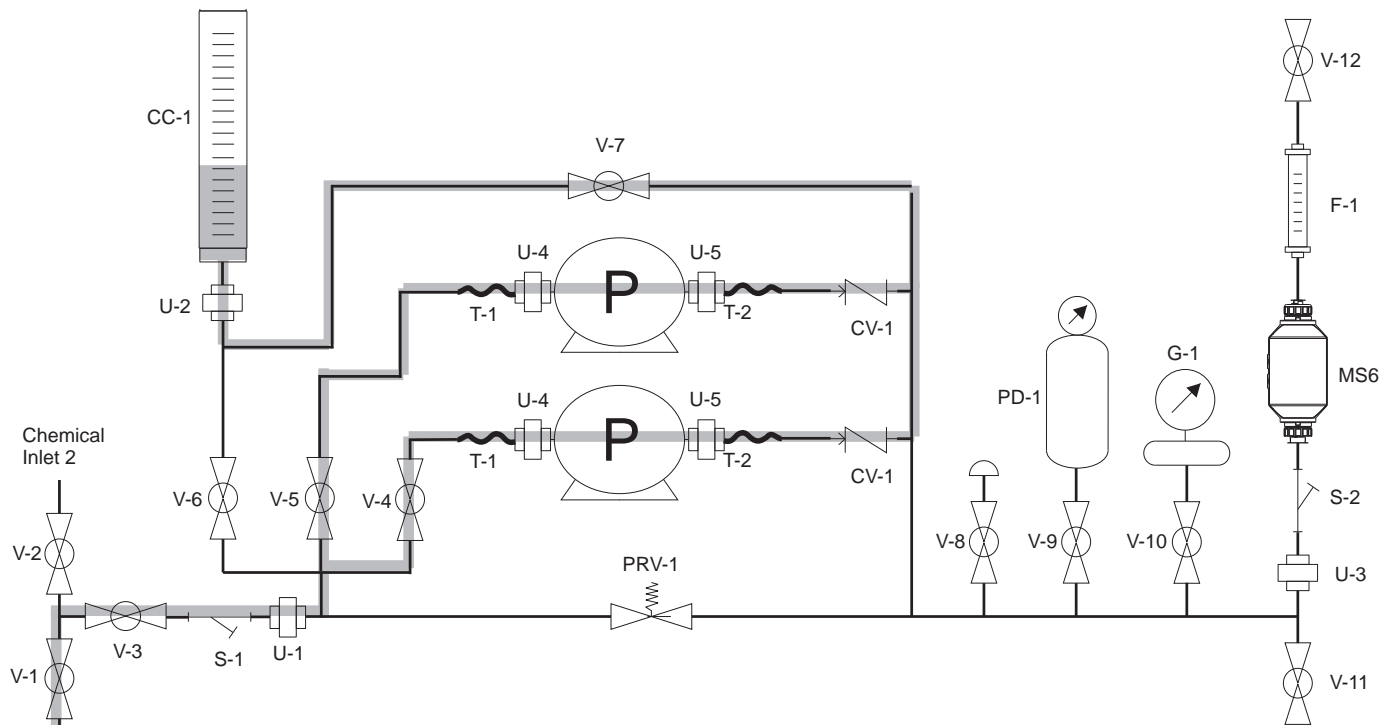

Peristaltic Pump Calibration Fluid Path

* Note: Calibration columns may be filled with gravity, instead of via pump. If supply tank is at a higher level than the calibration column, appropriate valves can be opened on the inlet to allow gravity feed into the calibration column. Slowly open and closed valve to calibration column to achieve the desired level. **Never leave skid unattended when filling calibration column.**

6.0 Maintenance

CAUTION: Proper eye protection and safety gear must be worn at all times when installing and servicing the pump.

6.1 Routine Inspection and Maintenance

The skid requires very little maintenance. However, the skid, pump, and all accessories should be checked weekly. This is especially important when pumping aggressive chemicals. Inspect all components for signs of leaking, swelling, cracking, discoloration or corrosion. Replace worn or damaged components immediately.

Cracking, crazing, discoloration and similar deterioration during the first week of operation are signs of severe chemical attack. If this occurs, immediately remove the chemical from the skid and pump. Determine which parts are being attacked and replace them with parts that have been manufactured using more suitable materials. The manufacturer does not assume responsibility for damage to the skid and pump that has been caused by chemical attack.

6.2 Charging Pulsation Dampener

The pulsation dampener may require initial and periodic charging to maintain effectiveness. **Refer to dampener manual for detailed instructions for charging.**

To charge the dampener:

- Determine the maximum actual operating pump system discharge pressure.
- Adjust pressurized air output pressure to a setting at/about pump system pressure. **Do Not Use Oxygen.**
- Remove cap from top of dampener air connection.
- Connect pressurized air line to the top connector of the dampener.
- Adjust valve to introduce air into dampener.
- Watch pressure gauge on dampener and close air valve when pressure reaches approximately 80-85% of system pressure.
- Close valve and remove air line from dampener.
- Once system pressure is in contact with the bladder/bellows, the gas charge will be compressed to the system pressure and the dampener gauge will read the system pressure, not the initial charge pressure.

6.3 Replacing the Bladder in the Pulsation Dampener

The pulsation dampener may require initial and periodic charging to maintain effectiveness. **Refer to dampener manual for detailed instructions for charging.**

[Click here for video instruction](#), or scan QR Code.



6.4 Pressure Relief Valve Maintenance

The pressure relief valve (PRV) provided with the skid will periodically require maintenance due to fouling and diaphragm or spring fatigue. Order KIT-PRV (diaphragm and spring) for this service.

To service the Pressure Relief Valve (PRV):

1. Relieve all pressure for skid system and flush as necessary.
2. Remove pressure relief valve from the skid.
3. Remove the black cap from adjustment stem.
4. Note depth of set screw with a marker on screwdriver or removal tool.
5. Remove set screw with flat head screwdriver or similar tool.
6. Unscrew four bottom screws with 5/32" allen wrench.
7. Remove the top portion on the valve.
8. Remove the spring, backing piece, and diaphragm.
9. Clean the valve seat and all internal surfaces with clean cloth.
10. Inspect valve seat for wear or corrosion.
11. Install the new diaphragm with PTFE (white) side down.
12. Install the support disc and new spring.
13. Place the top portion of valve back in place, and install/screw the set-screw to keep the spring from coming out.
14. Install screws and hand tighten evenly.
15. Then tighten the four screws to 3 ft-lbs torque.
16. Return set screw to previous setting.
17. Install the pressure relief valve in to the skid.
18. Tighten union nuts, and pressure test valve to ensure proper setting.

[Click here for video instruction](#), or scan QR Code.



6.5 Skid Component Replacement

Some skid components may require periodic replacement. Pay special attention to seals and gaskets, fittings connections, tubing connections between pump and skid piping, and other wearable parts.

Caution: Prior to any service or component replacement, ensure all system pressure is removed and all chemicals are drained. Adhere to facility safety procedures without exception.

Unionized components - The skid is designed so that components can be serviced and replaced easily.

- With all system pressure relieved and chemical flushed, loosen union connections.
- Remove component carefully.
- Service or replace component, as required. Inspect all surfaces and replace O-rings.
- Re-install component and tighten unions. Ensure any O-rings are seated properly.
- Confirm that component was installed in correct direction.
- Note replacement in service log.
- Re-start system according to manual and facility guidelines.

Installing replacement components (Calibration Column, Pressure Gauge, Dampener) - Be sure the replace components with identical or approved components.

- Follow installation guidelines per component manuals. Review all documentation.
 - Ensure all O-rings and gaskets are present and seated properly.
 - Ensure components are facing/oriented correctly and directionally correct.
 - Do not strain existing piping when connecting.
 - Tighten all union connections evenly.
 - Re-check/re-tighten other skid connections and hardware.
 - If necessary, pressure test system before placing in operation.
-

7.0 General Accessories and Parts List

7.1 Accessories

Part No.	Description
Calibration Columns	
CC-0100P	Calibration Cylinder, 100mL, PVC, 1/2" Socket
CC-0250P	Calibration Cylinder, 250mL, PVC, 1/2" Socket
CC-0500P	Calibration Cylinder, 500mL, PVC, 3/4" Socket
CC-1000P	Calibration Cylinder, 1000mL, PVC, 3/4" Socket
CC-2000P	Calibration Cylinder, 2000mL, PVC, 1" Socket
CC-4000P	Calibration Cylinder, 4000mL, PVC, 1" Socket
Pressure Gauges, Pressure Switches, and Gauge Guards	
90018-268	Pressure Gauge & Guard, PVC, 0-60 psi range, 2.5" dia. dial, 304/316SS, 1/2" Socket connection
90018-269	Pressure Gauge & Guard, PVC, 0-160 psi range, 2.5" dia. dial, 304/316SS, 1/2" Socket connection
90018-270	Pressure Gauge & Guard, PVC, 0-300 psi range, 2.5" dia. dial, 304/316SS, 1/2" Socket connection
90018-271	Pressure Gauge & Guard, CPVC, 0-60 psi range, 2.5" dia. dial, 304/316SS, 1/2" Socket connection
90018-272	Pressure Gauge & Guard, CPVC, 0-160 psi range, 2.5" dia. dial, 304/316SS, 1/2" Socket connection
90018-273	Pressure Gauge & Guard, CPVC, 0-300 psi range, 2.5" dia. dial, 304/316SS, 1/2" Socket connection
90018-283	Pressure Gauge & Guard, PVDF, 0-60 psi range, 2.5" dia. dial, 304/316SS, 1/2" Socket connection
90018-284	Pressure Gauge & Guard, PVDF, 0-160 psi range, 2.5" dia. dial, 304/316SS, 1/2" Socket connection
90018-285	Pressure Gauge & Guard, PVDF, 0-300 psi range, 2.5" dia. dial, 304/316SS, 1/2" Socket connection
90018-037	Pressure Switch, 10-100 psi range, 1/2" conduit connection, loose wires (60 in.), 316SS, 1/4" Male NPT connection
90018-103	Pressure Switch, 20-200 psi range, 1/2" conduit connection, loose wires (60 in.), 316SS, 1/4" Male NPT connection
90008-746	Gauge Guard, GGU050POTT, PTFE Diaphragm, PVC Body, 1/2" Socket x 1/4" Female NPT
90008-768	Gauge Guard, GGU050COTT, PTFE Diaphragm, PVC Body, 1/2" Socket x 1/4" Female NPT
90008-868	Gauge Guard, GGU050KOTT, PTFE Diaphragm, PVDF Body, 1/2" Socket x 1/4" Female NPT
Pressure Relief Valves	
90018-260	Pressure Relief Valve, True Union, 1/2" Socket, PVC Body, FKM Seals, PTFE Diaphragm
90018-261	Pressure Relief Valve, True Union, 1/2" Socket, PVC Body, EP Seals, PTFE Diaphragm
90018-262	Pressure Relief Valve, True Union, 1/2" Socket, CPVC Body, FKM Seals, PTFE Diaphragm
90018-263	Pressure Relief Valve, True Union, 1/2" Socket, CPVC Body, EP Seals, PTFE Diaphragm
90018-093	Pressure Relief Valve, True Union, 1/2" Socket, PVC Body, PTFE Seals, PTFE Diaphragm
90008-922	Pressure Relief Valve, True Union, 1" Socket, PVC Body, FKM Seals, PTFE Diaphragm
90018-264	Pressure Relief Valve, Unibody, 1/2" Socket, PVC Body, FKM Seals, PTFE Diaphragm
90018-265	Pressure Relief Valve, Unibody, 1/2" Socket, PVC Body, EP Seals, PTFE Diaphragm
90018-266	Pressure Relief Valve, Unibody, 1/2" Socket, CPVC Body, FKM Seals, PTFE Diaphragm
90018-267	Pressure Relief Valve, Unibody, 1/2" Socket, CPVC Body, EP Seals, PTFE Diaphragm
Back Pressure Valves	
90018-252	Back-Pressure Valve, True Union, 1/2" Socket, PVC Body, FKM Seals, PTFE Diaphragm
90018-253	Back-Pressure Valve, True Union, 1/2" Socket, PVC Body, EP Seals, PTFE Diaphragm
90018-254	Back-Pressure Valve, True Union, 1/2" Socket, CPVC Body, FKM Seals, PTFE Diaphragm
90018-255	Back-Pressure Valve, True Union, 1/2" Socket, CPVC Body, EP Seals, PTFE Diaphragm
90018-256	Back-Pressure Valve, Unibody, 1/2" Socket, PVC Body, FKM Seals, PTFE Diaphragm
90018-257	Back-Pressure Valve, Unibody, 1/2" Socket, PVC Body, EP Seals, PTFE Diaphragm
90018-258	Back-Pressure Valve, Unibody, 1/2" Socket, CPVC Body, FKM Seals, PTFE Diaphragm
90018-259	Back-Pressure Valve, Unibody, 1/2" Socket, CPVC Body, EP Seals, PTFE Diaphragm

7.2 Spare Parts

Part No.	Description
Ball Valves	
90008-786	Ball Valve, Vented, PVC, 1/2" Slip, FKM O-ring
90008-801	Ball Valve, Vented, PVC, 1/2" Slip, EP O-ring
90008-788	Ball Valve, Vented, CPVC, 1/2" Slip, FKM O-ring
90008-802	Ball Valve, Vented, CPVC, 1/2" Slip, EP O-ring
Strainer	
90008-898	Y-Strainer, PVC, 1/2", FKM O-ring
90008-910	Y-Strainer, PVC, 1/2", EP O-ring
90008-990	Y-Strainer, CPVC, 1/2", FKM O-ring
90008-991	Y-Strainer, CPVC, 1/2", EP O-ring
Flow Indicator	
FI-100-8SV	Flow Indicator, Acrylic Body, Ceramic Ball. 1/2" Slip, PVC, FKM O-ring
FI-100-8SE	Flow Indicator, Acrylic Body, Ceramic Ball. 1/2" Slip, PVC, EP O-ring
FI-100-8SV-CP	Flow Indicator, Acrylic Body, Ceramic Ball. 1/2" Slip, CPVC, FKM O-ring
FI-100-8SE-CP	Flow Indicator, Acrylic Body, Ceramic Ball. 1/2" Slip, CPVC, EP O-ring
Ball Valve Stand-off	
76002-047	Ball Valve Stand-off, PA12
Tubing	
75000-217	1/2" ID Reinforced PVC Tube, 2.5 ft
75000-342	1/2" ID Reinforced PVC Tube, 8 ft
C-335-6	1/4" x 3/8" Polyethylene Tubing, 5 ft
C-335-6-10	1/4" x 3/8" Polyethylene Tubing, 10 ft
75000-337	1/4" PTFE Tubing, 2.5 ft
75000-316	1/2" PTFE Tubing, 2.5 ft
Catch Basin Plug	
90018-225	Plug, Catch Basin, 3/8" NPT, PP

8.0 Troubleshooting

Caution: Skids contain chemicals and use electrical components. When troubleshooting issues with skids and pumps, always wear proper safety gear and safety glasses. Adhere to local safety protocols. Contact the factory when unsure about the proper operation of components or systems. Refer to a licensed electrician when modifying or testing electrical.

Common Issues

Air is entering the skid/pump piping. Check the suction lines to ensure all connections are tight. Check the level of the chemical tank. Remove obstructions and clean strainers. Replace O-rings as necessary to ensure the best seal.

Pump is not accurate or no flow. Check the suction line and clean the strainer. Check for closed valves and obstructions in suction lines, discharge lines, and injectors. Check the condition of the pump. Check discharge pressure and pressure relief valve for bypass.

The valves or fittings are leaking. Identify the exact location of the leak. Determine if the leak is from a location with an O-ring, weld, or crack. Take pictures and forward them to Blue-White® customer service. Simple O-ring seating or replacement may be needed. Ensure any replaced O-rings are of proper material. Pre-manufactured pipe sections can be purchased from Blue-White®.

Electricals

Check the specific instructions for the component. Remove the power and check the wiring connections. Use caution when working with wiring. Contact an electrical professional if you are unsure of the requirements. Keep power wiring separate from signal wiring. Use shielded cables for all signal wiring.

9.0 System

About the CFPS Chem-Feed Skid System

The CFPS Skid is designed to be simple and easy to operate. The CFPS Skid system may come with pumps installed. Pumps must be ordered separately. All necessary fittings and connectors are provided.

While the CFPS Skid Systems are standard and can be ordered with standard parts numbers, there may be some slight differences between skids, and some skids may be customized for a particular application. Certain components used in the skids may have changed or have been upgraded from previous versions. Note differences and changes on this manual on the following pages, as needed.

Check with the factory for specific information and questions on your skid.

Chemical Compatibility

Skid components vary in material composition. Blue-White® will strive to ensure components are compatible with the chemicals specified, but it is the user's and customer's responsibility to ensure all components provided with the skid are compatible with any chemicals used. Note that some components may be more susceptible to chemical attack.

System Updates

Certain skid components, such as pumps and flow meters, may require an occasional update. To check for firmware updates, visit the Blue-White® website product page and check the firmware documentation.

10.0 Warranty

LIMITED WARRANTY

Your Blue-White product is a quality product and is warranted for a specific time from date of purchase (proof of purchase is required). The product will be repaired or replaced at our discretion. Failure must have occurred due to defect in material or workmanship and not as a result of operation of the product other than in normal operation as defined in the product manual. Warranty status is determined by the product's serial label and the sales invoice or receipt. The serial label must be on the product and legible. The warranty status of the product will be verified by Blue-White or a factory authorized service center.

CHEM-FEED® skid systems are warranted for 2 years from date of purchase (proof of purchase is required). The system will be repaired or replaced at our discretion. The metering pump may have its own warranty and is not covered under this warranty.

WHAT IS NOT COVERED

- Pump removal, or re-installation, and any related labor charge.
- Freight to the factory, or service center.
- Products that have been tampered with, or in pieces.
- Damage resulting from misuse, carelessness such as chemical spills on the enclosure, abuse, lack of maintenance, or alteration which is out of our control.
- Damage by faulty wiring, power surges or acts of nature.

BLUE-WHITE does not assume responsibility for any loss, damage, or expense directly or indirectly related to or arising out of the use of its products. Failure must have occurred due to defect in material or workmanship and not as a result of operation of the product other than in normal operation as defined in the pump manual.

Warranty status is determined by the pump's serial label and the sales invoice or receipt. The serial label must be on the pump and legible. The warranty status of the pump will be verified by Blue-White or a factory authorized service center.

PROCEDURE FOR IN WARRANTY REPAIR

Warranty service must be performed by the factory or an authorized service center. Contact the factory or local repair center to obtain a RMA (Return Material Authorization) number. It is recommended to include foot strainer and injection/check valve fitting since these devices may be clogged and part of the problem. Decontaminate, dry, and carefully pack the product to be repaired. Please enclose a brief description of the problem and proof of purchase. Prepay all shipping and insurance cost. COD shipments will not be accepted. Damage caused by improper packaging is the responsibility of the sender. When In-Warranty repair is completed, the factory pays for return shipping to the dealer or customer.

PRODUCT USE WARNING

Blue-White products are manufactured to meet the highest quality standards in the industry. Each product instruction manual includes a description of the associated product warranty and provides the user with important safety information. Purchasers, installers, and operators of Blue-White products should take the time to inform themselves about the safe operation of these products. In addition, Customers are expected to do their own due diligence regarding which products and materials are best suited for their intended applications. BLUE-WHITE is pleased to assist in this effort but does not guarantee the suitability of any particular product for any specific application as Blue-White does not have the same degree of familiarity with the application that the customer/end user has. While BLUE-WHITE will honor all of its product warranties according to their terms and conditions, Blue-White shall only be obligated to repair or replace its defective parts or products in accordance with the associated product warranties.

BLUE-WHITE SHALL NOT BE LIABLE EITHER IN TORT OR IN CONTRACT FOR ANY LOSS OR DAMAGE WHETHER DIRECT, INDIRECT, INCIDENTAL, OR CONSEQUENTIAL, ARISING OUT OF OR RELATED TO THE FAILURE OF ANY OF ITS PARTS OR PRODUCTS OR OF THEIR UNSUITABILITY FOR A GIVEN PURPOSE OR APPLICATION.

CHEMICAL RESISTANCE WARNING

BLUE-WHITE offers a wide variety of wetted parts. Purchasers, installers, and operators of Blue-White products must be well informed and aware of the precautions to be taken when injecting or measuring various chemicals, especially those considered to be irritants, contaminants or hazardous. Customers are expected to do their own due diligence regarding which products and materials are best suited for their applications, particularly as it may relate to the potential effects of certain chemicals on Blue-White products and the potential for adverse chemical interactions. Blue-White tests its products with water only. The chemical resistance information included in this instruction manual was supplied to BLUE-WHITE by reputable sources, but Blue-White is not able to vouch for the accuracy or completeness thereof. While BLUE-WHITE will honor all of its product warranties according to their terms and conditions, Blue-White shall only be obligated to repair or replace its defective parts or products in accordance with the associated product warranties.

BLUE-WHITE SHALL NOT BE LIABLE EITHER IN TORT OR IN CONTRACT FOR ANY LOSS OR DAMAGE, WHETHER DIRECT, INDIRECT, INCIDENTAL, OR CONSEQUENTIAL, ARISING OUT OF OR RELATED TO THE USE OF CHEMICALS IN CONNECTION WITH ANY BLUE-WHITE PRODUCTS.

Users of electrical and electronic equipment (EEE) with the WEEE marking per Annex IV of the WEEE Directive must not dispose of end of life EEE as unsorted municipal waste, but use the collection framework available to them for the return, recycle, recovery of WEEE and minimize any potential effects of EEE on the environment and human health due to the presence of hazardous substances. The WEEE marking applies only to countries within the European Union (EU) and Norway. Appliances are labeled in accordance with European Directive 2002/96/EC. Contact your local waste recovery agency for a Designated Collection Facility in your area.

Blue-White®



Fluid metering solutions made simple



Users of electrical and electronic equipment (EEE) with the WEEE marking per Annex IV of the WEEE Directive must not dispose of end of life EEE as unsorted municipal waste, but use the collection framework available to them for the return, recycle, recovery of WEEE and minimize any potential effects of EEE on the environment and human health due to the presence of hazardous substances. The WEEE marking applies only to countries within the European Union (EU) and Norway. Appliances are labeled in accordance with European Directive 2002/96/EC.

Contact your local waste recovery agency for a *Designated Collection Facility* in your area.